

UNITED STATES PATENT AND TRADEMARK OFFICE

BEFORE THE PATENT TRIAL AND APPEAL BOARD

TELEBRANDS CORP.,
Petitioner,

v.

TINNUS ENTERPRISES, LLC,
Patent Owner.

Case PGR2017-00024
Patent 9,533,779 B2

Before MICHAEL W. KIM, FRANCES L. IPPOLITO, and
KEVIN W. CHERRY, *Administrative Patent Judges*.

IPPOLITO, *Administrative Patent Judge*.

DECISION
Denying Institution of Post-Grant Review
37 C.F.R. § 42.208

I. INTRODUCTION

Telebrands Corp. (“Petitioner”) filed a Petition (Paper 1, “Pet.”) for post-grant review of claims 1–13 of U.S. Patent No. 9,533,779 B2 (Ex. 1001, “the ’779 patent”). Tinnus Enterprises, LLC (“Patent Owner”) filed a Preliminary Response (Paper 9, “Prelim. Resp.”). We have authority under 35 U.S.C. § 324, which provides that a post-grant review may be instituted only if “the information presented in the petition . . . demonstrate[s] that it is more likely than not that at least 1 of the claims challenged in the petition is unpatentable.” *See also* 37 C.F.R. § 42.4(a) (“The Board institutes the trial on behalf of the Director.”). We determine that the information presented in the Petition does not demonstrate that it is more likely than not that Petitioner would prevail in showing that any of the challenged claims are unpatentable under the grounds of unpatentability asserted in the Petition. Accordingly, we do not institute a post-grant review of any of the challenged claims (i.e., claims 1–13) of the ’779 patent.

A. *Related Proceedings*

Petitioner indicates that the ’779 patent is involved in *Tinnus Enterprises, LLC v. Telebrands Corp.*, Civil Action No. 6:17-cv-00170-RWS-JDL (E.D. Tex.). Pet. 3.

Related U.S. Patent No. 9,051,066 B1 (“the ’066 patent”) is the subject of post-grant review in PGR2015-00018 involving the same parties (“the -00018 PGR”). The Board instituted trial in the -00018 PGR on January 4, 2016. *See Telebrands Corp. v. Tinnus Enterprises, LLC*, Case PGR2015-00018 (PTAB Jan. 4, 2016) (Paper 7) (“-00018 PGR DI.”). A final written decision in PGR2015-00018 issued on December 30, 2016 finding claims 1–6, 8, and 10–14 of the ’066 patent unpatentable for

indefiniteness under 35 U.S.C. § 112(b). *See Telebrands Corp. v. Tinnus Enterprises LLC*, Case PGR2015-00018 (PTAB Dec. 30, 2016) (Paper 75) (“-00018 PGR FD”). The -00018 PGR FD is the subject of an appeal to the Federal Circuit styled as *Tinnus Enterprises, LLC v. Telebrands Corp.*, No. 2017-1726 (Fed. Cir.). Paper 14, 4.

The ’066 patent is also involved in federal district court proceedings, *Tinnus Enterprises, LLC, et al. v. Telebrands Corp., et al.*, 6:15-cv-00551 RWS-JDL (E.D. Tex.) and *Tinnus Enterprises, LLC, et al. v. Telebrands Corp.*, Civil Action No. 6:17-cv-00199-RWS-JDL. Paper 14, 3–4. The Federal Circuit affirmed the district court’s decision granting a preliminary injunction in the 15-cv-000551 proceeding in *Tinnus Enterprises, LLC v. Telebrands Corp.*, 846 F.3d 1190 (Fed. Cir. 2017).

Additionally, related U.S. Patent Nos. 9,242,749 B2 (“the ’749 patent”) and 9,315,282 B2 (“the ’282 patent”) are the subject of post-grant review petitions filed by Petitioner in PGR2016-00030 and PGR2016-00031, respectively. *See* Paper 14, 2. We instituted post-grant reviews involving both patents on February 21, 2017. *See Telebrands Corp. v. Tinnus Enterprises, LLC*, Case PGR2016-00030 (PTAB Feb. 21, 2017) (Paper 16) (instituting post-grant review as to the ’749 patent); *Telebrands Corp. v. Tinnus Enterprises, LLC*, Case PGR2016-00031 (PTAB Feb. 21, 2017) (Paper 15) (instituting post-grant review as to the ’282 patent). We are informed that Petitioner is named as a defendant in federal district court cases involving the ’749 and ’282 patents—*Tinnus Enterprises, LLC v. Telebrands Corp.*, Civil Action No. 6:16-cv-00033-RWS-JDL (E.D. Tex.) and *Tinnus Enterprises, LLC v. Wal-Mart Stores, Inc.*, Civil Action No. 6:16-cv-00034-RWS-JDL (E.D. Tex.). Paper 14, 4. There are also appeals

PGR2017-00024
Patent 9,533,779 B2

pending at the Federal Circuit concerning the district court’s grant of a preliminary injunction against Petitioner regarding the ’749 and ’282 patents—*Tinnus Enterprises, LLC v. Telebrands Corp.*, Nos. 2017-1175, 2017-1760, 2017-1811 (Fed. Cir.). *Id.* at 4–5.

Related U.S. Patent No. 9,527,612 B2 (“the ’612 patent”) is also the subject of a post-grant review pending as PGR2017-00015. Post-grant review of the ’612 patent was instituted on October 11, 2017. *Tinnus Enterprises, LLC*, Case PGR2017-00015 (PTAB Oct. 11, 2017) (Paper 16) (instituting post-grant review as to the ’612 patent).

There are also three additional petitions for post-grant review currently pending—PGR2017-00040, PGR2017-00051, and PGR2017-00052. Paper 14, 2. Both the petition in the instant proceeding (PGR2017-00024) and PGR2017-00052 challenge U.S. Patent No. 9,533,779 B2. PGR2017-00040 challenges U.S. Patent No. 9,682,789 B2. PGR2017-00051 challenges the ’612 patent (also the subject of PGR2017-00015).

Patent Owner further indicates that patents commonly owned with the ’779 patent may be affected by a decision in *Tinnus Enterprises, LLC v. Wal-Mart Stores, Inc.*, No. 6:17-cv-00361 (E.D. Texas). Paper 14, 3.

B. The ’779 Patent

The ’779 patent, titled “System and Method for Filling Containers with Fluids,” issued January 3, 2017, from U.S. Application No. 14/929,787 (“the ’787 application”), filed November 2, 2015. Ex. 1001, at [54], [10], [21], [22]. The ’787 application is a continuation of U.S. Application No. 14/723,953, filed on May 28, 2015, which issued as the ’749 patent. *Id.* at [63]. The ’779 patent further claims the benefit of U.S. Provisional

Application No. 61/942,193 filed on February 20, 2014 and U.S. Provisional Application No. 61/937,083 filed on February 7, 2014. *Id.* at 1:7–17.¹

The '779 patent is directed generally to systems and methods for filling containers with fluids. Ex. 1001, Title. Figure 1 of the '779 patent is reproduced below.

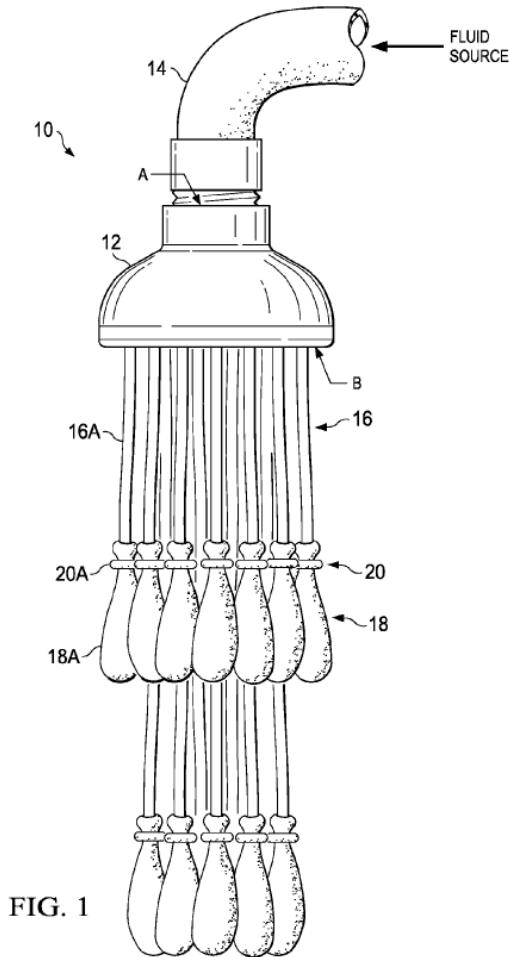

FIG. 1

¹ Because the earliest possible effective filing date for the '779 patent is after March 16, 2013 (the effective date for the first inventor to file provisions of the America Invents Act), and this petition was filed within 9 months of its issue date, the '779 patent is eligible for post-grant review. *See* 35 U.S.C. § 321(c).

Figure 1 is a simplified diagram illustrating an exemplary embodiment of system 10 for filling containers with fluids. *Id.* at 2:40–41. As shown in Figure 1, system 10 includes housing 12 removably attached to hose 14 at end A and to a plurality of hollow tubes 16 at end B. *Id.* at 2:42–44. A plurality of containers 18, such as water balloons, may be clamped to plurality of tubes 16 using elastic valves 20, which may comprise elastic fasteners, such as O-rings. *Id.* at 2:59–67. In one embodiment, containers 18 may fall off under gravity; for example, when filled containers 18 reach a threshold weight, they slip off tubes 16 due to gravity. *Id.* at 4:7–9. “The threshold weight may be based upon the tightness of elastic valves 20, friction between tubes 16 and containers 18, and force from the weight of containers 18 (among other parameters).” *Id.* at 4:10–13. Elastic valves 20 or fasteners may constrict the necks of containers 18, sealing them, when the containers slide off tubes 16. *Id.* at 4:14–15.

C. Illustrative Claim

Of the challenged claims, claims 1, 5, 8, and 11 are independent. Independent claim 1, reproduced below, is illustrative of the claimed subject matter:

1. An apparatus for simultaneously filling balloons, comprising:
 - a fitting comprising an inlet and at least three outlets; and
 - at least three branch assemblies coupled to the fitting, each branch assembly comprising:
 - a tube extending from the fitting at a respective one of the at least three outlets;

a balloon with a neck disposed around an end of the tube; and

an elastic ring compressing the neck of the balloon around the end of the tube, the elastic ring configured to restrict detachment of the balloon from the tube and to automatically seal the balloon upon detachment of the balloon from the tube, the restriction of the elastic ring being limited such that the balloon, if filled with a sufficient amount of water, is detachable by gravity or by gravity combined with a manually applied acceleration of the tube.

D. The Asserted References

Petitioner relies upon the following references (Pet. 16–19):

Reference	Patent or Pub. No. or Description	Date	Exhibit No.
Cooper	US 5,826,803	Oct. 27, 1998	Ex. 1029
Saggio	US 2013/0118640 A1	May 16, 2013	Ex. 1011
Lee	US 2005/0004430 A1	Jan. 6, 2005	Ex. 1012
Donaldson	US 5,014,757	May 14, 1991	Ex. 1013
Weir	US 6,478,651 B1	Nov. 12, 2002	Ex. 1015
Pomerantz	US 5,509,540	Apr. 23, 1996	Ex. 1031
ZORBZ Replicator video	YouTube video showing prototype of ZORBZ Replicator	Aug. 19, 2014	Ex. 1032 and Ex. 1033

Petitioner also relies on the Declaration of Dr. Ken Kamrin (Ex. 1020).

E. The Asserted Grounds

Petitioner challenges claims 1–13 of the '779 patent on the following grounds (Pet. 17–19):

Reference(s)	Basis	Claims Challenged
	§ 112(a) for lack of written description	2, 4, 7, 10, and 13
	§ 112(b) for indefiniteness	1–13
Saggio and Donaldson	§ 103	1, 3–7, and 11–13
Saggio and Lee	§ 103	1, 3–7, and 11–13
Saggio, Cooper, and Lee or Donaldson	§ 103	2
Saggio, Cooper, Weir, and Donaldson or Lee	§ 103	5–7
Saggio, Pomerantz, and Donaldson or Lee	§ 103	8–10
Saggio, Donaldson or Lee, Cooper or Weir, and Pomerantz	§ 103	8–10
Zorbz and Donaldson or Lee	§ 103	1–13

II. ANALYSIS

A. Discretion under 35 U.S.C. § 325(d)

Our discretion as to whether to institute a post-grant review is guided, in part, by 35 U.S.C. § 325(d), which provides: “[T]he Director may take into account whether, and reject the petition or request because, the same or substantially the same prior art or arguments previously were presented to the Office.” 35 U.S.C. § 325(d); *see generally* *Cultec, Inc. v. Stormtech LLC*, Case IPR2017-00777 (PTAB Aug. 22, 2017) (Paper 7) (informative), *Hospira, Inc. v. Genentech, Inc.*, Case IPR2017-00739 (PTAB July 27, 2017) (Paper 16) (informative), *Unified Patents, Inc. v. Berman*, Case IPR2016-01571 (PTAB Dec. 14, 2016) (Paper 10) (informative); *see also*

Neil Ziegmann N.P.Z., Inc. v. Stephens, Case IPR2015-01860, slip op. 6–14 (PTAB Sept. 6, 2017) (Paper 13) (expanded panel) (explaining the rationale and purpose of § 325(d)).

Our discretion under § 325(d) involves a balance between competing interests. *See Hospira*, slip op. at 18. “On the one hand, there are the interests in conserving the resources of the Office and granting patent owners repose on issues and prior art that have been considered previously.” *Id.* (quoting *Fox Factory, Inc. v. SRAM, LLC*, Case IPR2016-01876, slip op. 7 (PTAB Apr. 3, 2017) (Paper 8)). “On the other hand, there are the interests of giving petitioners the opportunity to be heard and correcting any errors by the Office in allowing a patent” *Id.*

With respect to Petitioner’s obviousness challenges, Patent Owner argues that the references relied on by Petitioner in the present Petition were considered during prosecution of the ’779 patent. Prelim. Resp. 21–26. More specifically, Patent Owner asserts that for all of Petitioner’s obviousness grounds, Petitioner relies on either Donaldson or Lee for the claimed “elastic ring” limitation. *Id.* at 23 (citing Pet. 17–19). In this respect, Patent Owner asserts that the same or substantially the same arguments presented in the Petition were considered by the Examiner in his reasons for allowance. *See id.* at 26 (“the Examiner already considered the inherent teachings of the prior art—including Donaldson and Lee—and found that those teachings did not render the claims unpatentable.”).

Patent Owner also argues that we should deny the written description ground asserted in the Petition against claims 4, 7, 10, and 13 because “the Examiner already found during original prosecution that the disputed language of claims 4, 7, 10, and 13—namely, the limitation that ‘the tube

automatically restrains the fluid’—is ‘supported by the figures of the provisional applications’ (Ex. 1008 at 87-88.)” *Id.* at 27.

We agree with Patent Owner that we should exercise our discretion in denying institution of review based on Petitioner’s § 103 challenges because the same art and arguments were considered by the Examiner during the original prosecution. There is no dispute that Saggio and Lee were expressly considered by the Examiner and discussed in the Examiner’s Reasons for Allowance in the May 24, 2016 Notice for Allowance. *See* Ex. 1008, 86–88. In the Notice of Allowance, the Examiner considered expressly the teachings of Saggio and Lee, and explained in detail that neither one of these disclosed the claimed “elastic fastener.” *Id.* Moreover, the Examiner expressly also considered Donaldson and found that it was “cumulative with Lee [] in that both references disclose that moving mechanical components must be used to detach the balloons.” *Id.* at 17.

Additionally, the Examiner stated explicitly that “[n]one of the prior art teaches the subject matter in lines 7-11 of claim 31, which is present in all of the independent claims, and which is interpreted in accordance with *In re Swinehart*, 439 F.2d 210, 213 (CCPA 1971) and MPEP 2114.” Ex. 1008, 87. Claim 31 later issued as independent claim 1 of the ’779 patent. During prosecution, lines 7–11 of claim 31 recited:

elastic ring configured to restrict detachment of the balloon from the tube and to automatically seal the balloon upon detachment of the balloon from the tube, the restriction of the elastic ring being limited such that the balloon, if filled with a sufficient amount of water, is detachable by gravity or by gravity combined with a manually applied acceleration of the tube.

Id. at 184 (Examiner’s Amendment of claim 31). In this regard, the Examiner explicitly considered the prior art of record and stated that *none of*

the prior art teaches this claimed subject matter. Ex. 1008, 87. The prior art of record considered by the Examiner included all the references asserted in the Petition. *Id.* at 169–172, 174, 175, 178.

Further, we note that multiple Notices of Allowance were issued during prosecution of the '779 patent, several of them after applicants submitted various documents from other related proceedings before the Board, including the petitions in PGR2016-00030 and PGR2016-00031. Ex. 1008, 25–30, 37–38. These Petitions contained obviousness challenges against claims of the '749 patent and the '282 patent based on similar arguments and the same art (i.e., Saggio, Cooper, Weir, Donaldson, and Lee) at issue in the instant proceeding. The Examiner appears to have considered them. *Id.* at 20 The Examiner's reasoning for allowance remained unchanged after considering all the prior art of record, including the petitions filed in PGR2016-00030, PGR2016-00031, Saggio, Cooper, Lee, Donaldson, ZORBZ, Weir, and Pomerantz. Ex. 1008, 17.

On the whole, the prosecution history of the '779 patent reflects that the Examiner was presented and reviewed all the references relied upon for the obviousness challenges in the instant Petition. Further, the Examiner also reviewed similar obviousness challenges based on the same art that were presented in the petitions for PGR2016-00030 and PGR2016-00031. Ultimately, the Examiner determined that, after expressly reviewing all of the aforementioned evidence, “the prior art does not support a rejection of the currently pending claims” and “[n]one of the prior art teaches the subject matter” of the claimed “elastic ring.” Thus, the interests of finality and conservation of resources weigh heavily in favor of denying reconsideration of those same references and very same issues.

Petitioner's arguments to the contrary are not persuasive. First, Petitioner argues that the present record is different than the one before the Examiner. Pet. 80. In particular, Petitioner asserts that the testimony of Dr. Kamrin was not before the Examiner. *Id.* Petitioner contends that "one of the issues in this petition is inherency of the prior art references, which benefits from the consideration of expert testimony." *Id.* at 81. Nonetheless, having reviewed the record, we disagree with Petitioner's position. The technology here does not appear to be particularly complex, and the Examiner's explanation shows that he expressly considered the issues of inherency, and offered detailed findings why the functional limitations related to the elastic fastener were not necessarily present in the art at issue. *See* Ex. 1008, 87–88. Although not referred to expressly in the Examiner's explanation, the Information Disclosure Sheet considered by the Examiner includes the Petitions in PGR2016-00030 and PGR2016-00031, which contain similar explanations of inherency to those at issue in this case. *See* PGR2016-00031, Paper 2, 43–45 (Petition discussing inherency issue with respect to Lee). Although the Examiner's explanation does not refer to those papers expressly, the fact that those papers were listed on an IDS is, nevertheless, circumstantial evidence that Petitioner's inherency arguments were considered when the Examiner provided his explanation concerning inherency. *See* Ex. 1008, 87 ("Because it is not true that all elastic bands have the same elastic force as an inherent property, it cannot be presumed that all elastic bands would function the same way."). Moreover, as Patent Owner notes, Dr. Kamrin fails to even address Donaldson's use of a mechanical means, i.e., a spring, to release the balloon. Prelim. Resp. 32. Thus, we are not persuaded that Dr. Kamrin's testimony meaningfully

distinguishes the record that is before us from the record that was before the Examiner.

Second, Petitioner argues that the Examiner failed to consider the prior art combinations recited in this Petition. Pet. 81. As discussed above, the Examiner expressly considered the rubber band 2 of Lee in conjunction with Saggio. *See* Ex. 1008, 87–88. Further, the Examiner explicitly stated that “[n]one of the prior art teaches the subject matter” of the claimed “elastic ring.” On this record, we are persuaded that the prosecution history of the ’779 patent supports Patent Owner’s position that the Examiner also considered Donaldson, which was prior art of record during prosecution of the ’779 patent (*see* Ex. 1001, [56]), and was, further, relied upon in the Petitions for PGR2016-00030 and PGR2016-00031 regarding the elastic fastener limitations at issue in those proceedings. Further, the other references are not cited by Petitioner as compensating for any deficiency in Lee or Donaldson in this regard. Thus, we are unpersuaded that Petitioner has shown that the particular combinations at issue here would have made a difference in the Examiner’s conclusion, and are further unpersuaded that these proposed combinations are enough to justify reconsidering what the Examiner concluded already.

Additionally, we also agree with the Patent Owner that Petitioner’s written description challenge to claims 4, 7, 10, and 13 was already considered during prosecution by the Examiner. These claims share the same limitation, “if one of the balloons of the at least three branch assemblies detaches from its tube, the tube automatically restrains the fluid exiting therefrom,” which Petitioner asserts is unsupported by the text of the Specification or the figures of the ’779 patent. Pet. 23–24. However, in the

May 24, 2016 Notice of Allowance, the Examiner expressly determined that “[t]he language of claims 38, 46, 54, and 60 is supported by the figures of the provisional applications – as explained by Applicant, each tube functions to restrain the fluid even if a balloon is detached by virtue of the small cross section of the tube.” Ex. 1008, 87–88.² Petitioner refers to the figures in the provisional and, essentially, disagrees with the Examiner’s conclusion. Nonetheless, we discern that the Examiner considered the same exact issue and, ultimately, determined that the provisional applications provided sufficient support for claims 4, 7, 10, and 13. In consideration of the record before us, including the detailed reasons for allowance provided by the Examiner, we agree with Patent Owner that there is a lack of persuasive reasons to reconsider the Examiner’s determinations on these issues.

Accordingly, we determine that facts of this case weigh in favor of us exercising our discretion and declining to institute on the obviousness grounds and the written description challenge against claims 4, 7, 10, and 13 presented in the Petition.

B. Level of Skill in the Art

Petitioner asserts that a person of ordinary skill in the art at the time of the effective filing date of the ’779 patent (“POSA”) was a person having general knowledge about, and experience with, expandable containers, including, without limitation, balloons, and at least an associate’s degree in a technical science or engineering. Pet. 19 (citing Ex. 1020 ¶¶ 10–14).

For purposes of this Decision, we agree with Petitioner and determine that a POSA would have been a person having a general knowledge about,

² Claims 38, 46, 54, and 60 issued as claims 4, 7, 10, and 13.

and experience with, expandable containers, including, without limitation, balloons, and at least an associate's degree in mechanical engineering, or the equivalent. This level of skill is consistent with the types of problems and solutions described in the '779 patent and cited prior art.

C. Claim Construction

In a post-grant review, the Board gives claim terms in an unexpired patent their broadest reasonable interpretation in light of the specification of the patent in which they appear. 37 C.F.R. § 42.200(b).

For the purposes of this Decision, none of our determinations regarding Petitioner's proposed grounds of unpatentability requires us to interpret expressly any claim term.

D. Challenge under 35 U.S.C. § 112(a) for Lack of Written Description – Claim 2

To satisfy the written description requirement under 35 U.S.C. § 112(a), the specification must sufficiently describe an invention understandable to a person of ordinary skill in the art and “show that the inventor actually invented the invention claimed.” *Ariad Pharms., Inc. v. Eli Lilly & Co.*, 598 F.3d 1336, 1351 (Fed. Cir. 2010) (en banc). In other words, a patent applicant must “convey with *reasonable clarity* to those skilled in the art that, as of the filing date sought, he or she was in possession *of the invention*. The invention is, for purposes of the ‘written description’ inquiry, *whatever is now claimed*.” *Vas-Cath Inc. v. Mahurkar*, 935 F.2d 1555, 1563–64 (Fed. Cir. 1991). “Such description need not recite the claimed invention in haec verba but must do more than merely disclose that which would render the claimed invention obvious.” *ICU Med., Inc. v. Alaris Med. Sys., Inc.*, 558 F.3d 1368, 1377 (Fed. Cir. 2009). “An

applicant’s disclosure obligation varies according to the art to which the invention pertains.” *In re Hayes Microcomputer Prods., Inc. Patent Litig.*, 982 F.2d 1527, 1534 (Fed. Cir. 1992).

Petitioner asserts that the limitation, “the outlets are not disposed along a single line with respect to each other, and the tubes each extend from the fitting in the same direction,” recited in claim 2, is not supported by the written description of the ’779 patent. *See* Pet. 21–23. Specifically, Petitioner asserts that the broadest reasonable interpretation of a “single line” means any curved or straight line, and all “outlets extending through the fitting will *necessarily* be disposed along a single line.” Pet. 22 (citing Ex. 1020 ¶ 27). To illustrate this point, Petitioner submits an image showing a spiral drawn through dots of an “array.” Petitioner’s figure is reproduced below.

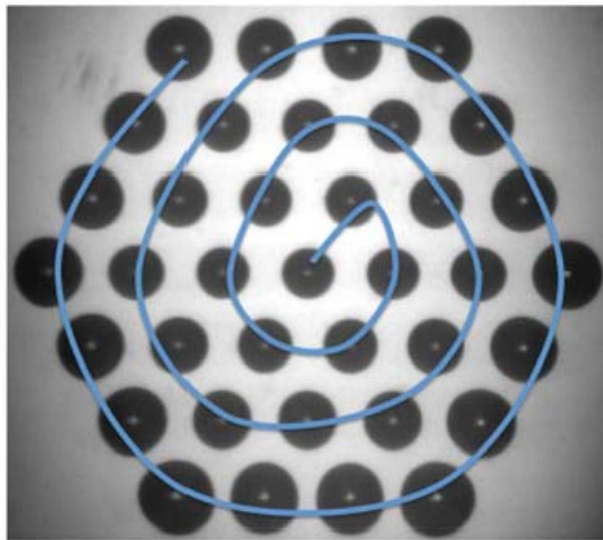

According to Petitioner, the figure above shows an array in which “each of the holes in the array is along the *same* single, curved line.” Pet. 22 (citing Ex. 1020 ¶ 28).

In response, Patent Owner contends that the '779 patent provides sufficient written description because it describes

Housing 12 comprises . . . *an array of holes* 26 at end B. Internal cavity 24 facilitates distributing the fluid entering at threaded opening 22 to *array of holes* 26 at end B. . . . *Array of holes* 26 may be configured for connecting first ends 28 of tubes 16 by any suitable means. . . . In some embodiments, a number of holes 26 in housing 12 and a number of tubes 16 can correspond to a number of containers 18 that are desired to be filled and sealed substantially simultaneously.

Prelim. Resp. 44 (citing Ex. 1001, 4:41–56). Patent Owner further asserts that a person of ordinary skill in the art would have further understood that when holes are arranged in columns and rows, there are at least three holes not disposed on a single straight line. Prelim. Resp. 44–45.

Based on this record, Patent Owner's arguments are persuasive. First, we note that Petitioner's construction effectively reads out the "*the outlets are not disposed along a single line with respect to each other,*" limitation from claim 2. In particular, Petitioner asserts that "outlets extending through the fitting will *necessarily* be disposed along a single line," and Dr. Kamrin testifies that "one can always draw a single line between outlets where tubes extend in the same direction." Pet. 22; Ex. 1020 ¶ 29. In other words, Petitioner's position is that because claim 2 requires that "the tubes each extend from the fitting in the same direction," then the outlets necessarily will always be disposed along a single line. *See* Pet. 22. However, claim 2 recites both that (1) "the outlets are not disposed along a single line with respect to each other" and (2) "the tubes each extend from the fitting in the same direction." Thus, Petitioner's construction of "single line" renders superfluous the limitation that "the outlets *are not disposed along a single line* with respect to each other," because, under Petitioner's construction,

any set of outlets, in any alignment, will necessarily be disposed on a single line. Precedent disfavors such a construction. *See Innova/Pure Water, Inc. v. Safari Water Filtration Sys.*, 381 F.3d 1111, 1119–20 (Fed. Cir. 2004) (“While not an absolute rule, all claim terms are presumed to have meaning in a claim.”); *Merck & Co. v. Teva Pharms. USA, Inc.*, 395 F.3d 1364, 1372 (Fed. Cir. 2005) (“A claim construction that gives meaning to all the terms of the claim is preferred over one that does not do so.”); *Power Mosfet Techs., L.L.C. v. Siemens AG*, 378 F.3d 1396, 1410 (Fed. Cir. 2004) (“[I]nterpretations that render some portion of the claim language superfluous are disfavored.”). On this record, Petitioner has not explained sufficiently and persuasively why this proposed construction is the broadest reasonable interpretation of the claimed phrase “the outlets are not disposed along a single line with respect to each other,” given the express claim language.

Second, claim construction aside, we are not persuaded that Petitioner’s written description arguments concerning the language of claim 2 are supported adequately by the record. Petitioner’s expert, Dr. Kamrin, does not sufficiently explain the basis for his testimony that the annotated image (reproduced below for convenience) is an array that is relevant to the ’779 patent, and, more particularly, to the subject matter of challenged claim 2.

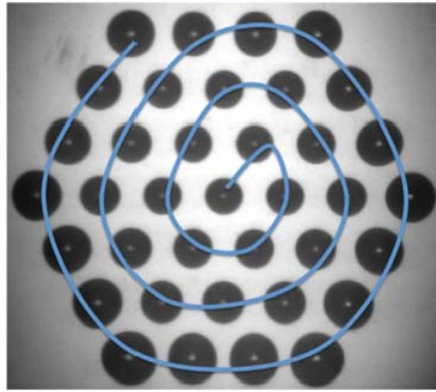

Both Dr. Kamrin and Petitioner agree that the '779 patent describes a housing with an array of holes. Pet. 22; Ex. 1020 ¶ 28. Nonetheless, neither the Petitioner nor Dr. Kamrin explain how the image (shown above) for convenience) is an array of holes extending through an end of a housing. *Id.* On this record, it is unclear at best how the annotated image shows an “array,” tubes extending in the same direction, or “a single line” as described in the context of the '779 patent. *See* 37 C.F.R. § 42.65(a) (“Expert testimony that does not disclose the underlying facts or data on which the opinion is based is entitled to little or no weight.”). Moreover, as indicated above, the annotated image works against Petitioner’s position, because its interpretation of the limitation, “the outlets are not disposed along a single line with respect to each other,” effectively reads out this requirement because, according to Petitioner, a line can be drawn through any and all of the holes. Accordingly, Petitioner has not demonstrated that it would more likely than not prevail on the ground that claim 2 is unpatentable for lack of written description pursuant to 35 U.S.C. § 112(a).

*E. Challenge under 35 U.S.C. § 112(b) for Indefiniteness – Claims
1–13*

1. Legal Standard

In reviewing indefiniteness of a claim, we consider whether the claim language is “cast in clear—as opposed to ambiguous, vague, indefinite—terms.” *In re Packard*, 751 F.3d 1307, 1313 (Fed. Cir. 2014); *see* Manual of Patent Examining Procedure (“MPEP”) § 2173.02(II) (Rev. 07.2015, Nov. 2015) (advising Examiners that the indefiniteness standard is whether “the language of the claim is such that a person of ordinary skill in the art could not interpret the metes and bounds of the claim so as to understand how to avoid infringement” (citation omitted)). Exact precision is not required. The test for determining the question of indefiniteness may be formulated as whether the claims “set out and circumscribe a particular area with a reasonable degree of precision and particularity.” *In re Moore*, 439 F.2d 1232, 1235 (CCPA 1971). With regard to the reasonableness standard, one must consider the language in the context of the circumstances. *In re Packard*, 751 F.3d at 1313.

2. “the restriction of the elastic ring being limited such that the balloon, if filled with a sufficient amount of water, is detachable by gravity or by gravity combined with a manually applied acceleration of the tube.”

Petitioner contends that the term “‘sufficient amount’ of water” in the challenged claims is indefinite under 35 U.S.C. § 112(b), because the ’779 patent does not provide objective boundaries to define how much water is a “sufficient amount.” Pet. 28 (citing Ex. 1020 ¶ 44). Petitioner contends that a “sufficient amount” of water can be any subjective amount of water, rendering claims 1–13 of the ’779 patent indefinite. *Id.* Petitioner adds that

whether the balloons will release from the tubes depends upon a number of factors including the mass of the balloon when filled with a subjective amount of water and the value of the manually applied acceleration. *Id.*³ (citing Ex. 1020 ¶ 46).

Patent Owner responds that the claims themselves objectively define the “sufficient amount” of water limitation, because the container is filled with a sufficient amount of water when it detaches “by gravity or by gravity combined with a manually applied acceleration of the tube,” as recited by the independent claims. Prelim. Resp. 42. Patent Owner further asserts that a person of ordinary skill in the art would know when the amount of water is sufficient “when it detaches from the tube.” *Id.*

Based on our review of the record, including the claim language and the Specification of the ’779 patent, we agree with Patent Owner’s position. Here, the restriction of the claimed elastic ring is limited such that the balloon, if filled with a sufficient amount of water, is detachable by (1) gravity or (2) by gravity combined with a manually applied acceleration of the tube. Further, we agree with Patent Owner’s explanation that a person of ordinary skill in the art would know when the amount of water has reached a “sufficient amount,” because the elastic rings would allow detachment by gravity or by gravity and manually applied acceleration of the tube. *See* Prelim. Resp. 42. Indeed, the claim language itself provides the conditions

³ We note that Petitioner also argues that instituting on this ground would be consistent with our construction of “filled” in PGR2015-00018. Pet. 28. However, here, Petitioner’s indefiniteness challenge is based on the “sufficient amount’ of water” claim language that is not at issue in PGR2015-00018 (i.e., “filled”). As such, we do not find the determinations in PGR2015-00018 to be controlling here.

for determining which elastic rings fall within, and outside, the scope of the claims based on the functional limitations recited in the claims.

This reading of claims 1–13 is consistent with the Specification of the ’779 patent, which provides examples of how containers may be detached from tubes. These examples include having filled containers reach a threshold weight to slip off tubes due to gravity, and the application of an acceleration (i.e., shaking) on the housing tubes to detach containers from tubes. Ex. 1001, 3:59–60, 3:64–66, 4:2–4, 4:7–18. Moreover, that the limitation at issue covers a broad range of elastic fastener does not render it indefinite. Claim breadth does not equal indefiniteness. *See In re Miller*, 441 F.2d 689, 693 (CCPA 1971) (“[B]readth [of a claim] is not to be equated with indefiniteness.”).

III. CONCLUSION

After due consideration of the record before and for the foregoing reasons, we deny institution of a post-grant review.

IV. ORDER

In consideration of the foregoing, it is hereby:

ORDERED that the Petition is denied as to all challenged claims of the ’779 patent and no trial is instituted.

PGR2017-00024
Patent 9,533,779 B2

PETITIONER:

Robert T. Maldonado
Tonia Sayour
Elana Araj
COOPER & DUNHAM LLP
rmaldonado@cooperdunham.com
tsayour@cooperdunham.com
earaj@cooperdunham.com

Eric Maurer
BOIES, SCHILLER, & FLEXNER LLP
emaurer@bsflp.com

PATENT OWNER:

Robert Sterne
Jason Eisenberg
Jonathan Tuminaro
Dallin Glenn
STERNE, KESSLER, GOLDSTEIN & FOX P.L.L.C.
rsterne@skgf.com
jasone-ptab@skgf.com
jtuminar-ptab@skgf.com
dglenn-ptab@skgf.com